



Unified International  
Mathematics Olympiad

**UNIFIED INTERNATIONAL MATHEMATICS OLYMPIAD (UPDATED)**

**CLASS - 10**

**Question Paper Code : UM 9274**

**KEY**

<b>1</b>	<b>2</b>	<b>3</b>	<b>4</b>	<b>5</b>	<b>6</b>	<b>7</b>	<b>8</b>	<b>9</b>	<b>10</b>
D	B	C	C	C	A	A	D	C	D
<b>11</b>	<b>12</b>	<b>13</b>	<b>14</b>	<b>15</b>	<b>16</b>	<b>17</b>	<b>18</b>	<b>19</b>	<b>20</b>
D	Delete	D	C	A	A	B	D	D	A
<b>21</b>	<b>22</b>	<b>23</b>	<b>24</b>	<b>25</b>	<b>26</b>	<b>27</b>	<b>28</b>	<b>29</b>	<b>30</b>
C	D	C	B	D	A	B	A	C	B
<b>31</b>	<b>32</b>	<b>33</b>	<b>34</b>	<b>35</b>	<b>36</b>	<b>37</b>	<b>38</b>	<b>39</b>	<b>40</b>
B,C,D	B,D	B,C,D	A,C	A,B,C,D	A	C	A	C	A
<b>41</b>	<b>42</b>	<b>43</b>	<b>44</b>	<b>45</b>	<b>46</b>	<b>47</b>	<b>48</b>	<b>49</b>	<b>50</b>
C	B	C	A	C	B	D	B	B	D

**EXPLANATIONS**

**MATHEMATICS**

1. (D) Let the two sides of the triangle be  $x$  and  $y$ , then
- $$41^2 = x^2 + y^2 \Rightarrow x^2 + y^2 = 1681$$
- and  $\frac{1}{2}xy = 180 \Rightarrow xy = 360$
- $$(x + y)^2 = x^2 + y^2 + 2xy = 1681 + 720 = 2401$$
- $\Rightarrow x + y = 49 \Rightarrow x - y = \sqrt{(x + y)^2 - 4xy}$
- $\Rightarrow x - y = 31$  which is the required difference.

2. (B) Given equations are
- $$2x + 3y = 5 \quad \dots (1)$$
- $$\text{and } x - y = 10 \quad \dots (2)$$
- Multiplying eq. (2) by 3 and adding eq. (1) and eq. (2), we get
- $$5x = 35$$
- $$\Rightarrow x = 7$$
- and  $y = -3$ .
- $\therefore$  The point  $(x, y)$  at which the submarine can be destroyed is  $(7, -3)$ .

3. (C)  $(\sin x - \cos x)^4 = [(\sin x - \cos x)^2]^2$   
 $= (\sin^2 x + \cos^2 x - 2\sin x \cos x)^2$   
 $= (1 - 2\sin x \cos x)^2$   
 $= 1 + 4\sin^2 x \cos^2 x - 4\sin x \cos x$   
 $(\sin x + \cos x)^2 = \sin^2 x + \cos^2 x + 2\sin x \cos x$   
 $= 1 + 2\sin x \cos x$   
 $\sin^6 x + \cos^6 x = (\sin^2 x)^3 + (\cos^2 x)^3$   
 $= (\sin^2 x + \cos^2 x)^3$   
 $- 3\sin^2 x \cos^2 x (\sin^2 x + \cos^2 x)$   
 $= 1^3 - 3\sin^2 x \cos^2 x (1)$   
 $= 1 - 3\sin^2 x \cos^2 x$   
 $\therefore \text{LHS} = 3(1 + 4\sin^2 x \cos^2 x - 4\sin x \cos x)$   
 $+ 6(1 + 2\sin x \cos x) + 4(1 - 3\sin^2 x \cos^2 x)$   
 $= 3 + 12\sin^2 x \cos^2 x - 12\sin x \cos x$   
 $+ 6 + 12\sin x \cos x + 4 - 12\sin^2 x \cos^2 x$   
 $= 13$

4. (C)

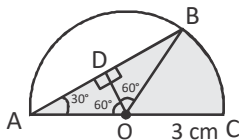

Construction:-

Join OB and  $OD \perp AB$

In  $\triangle AOD$ ,  $\sin 30^\circ = \frac{OD}{AO}$

$$\frac{1}{2} = \frac{OD}{3 \text{ cm}}$$

$$OD = \frac{3}{2} \text{ cm}$$

$$\cos 30^\circ = \frac{AD}{AO}$$

$$\frac{\sqrt{3}}{2} = \frac{AD}{3 \text{ cm}}$$

$$AD = \frac{3\sqrt{3} \text{ cm}}{2}$$

$$AB = 2 \times AD$$

$$= 2 \times \frac{3\sqrt{3}}{2} \text{ cm}$$

Area of the shaded region

= Area of  $\triangle AOB$  + area of the sector BOC

$$= \frac{1}{2} \times AB \times OD + \frac{x}{360^\circ} \times \pi r^2$$

$$= \frac{1}{2} \times 3\sqrt{3} \text{ cm} \times \frac{3}{2} \text{ cm} + \frac{60^\circ}{360^\circ} \times 3.14 \times 3 \times 3 \text{ cm}^2$$

$$= \frac{9 \times 1.73}{4} \text{ cm}^2 + \frac{1}{6} \times 3.14 \times 3 \times 3 \text{ cm}^2$$

$$= \frac{15.57}{4} \text{ cm}^2 + 4.71 \text{ cm}^2$$

$$= 3.8958 \text{ cm}^2 + 4.71 \text{ cm}^2$$

$$= 8.6025 \text{ cm}^2$$

5. (C)  $\triangle ABC \cong \triangle DCB$ ,

$$\therefore \frac{AF}{CF} = \frac{AB}{CD} = \frac{80}{20} = \frac{4}{1}$$

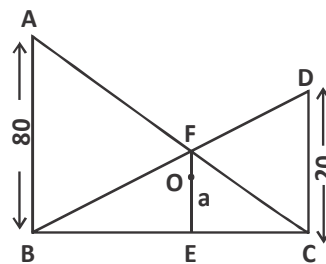

$$\Rightarrow \frac{AF}{CF} = \frac{4}{1}$$

$$\Rightarrow \frac{AF + FC}{FC} = \frac{4 + 1}{1} = \frac{5}{1}$$

$\triangle ABC \sim \triangle FEC$  [Since AB and FE are parallel]

$$\Rightarrow \frac{AB}{FE} = \frac{AC}{FC}$$

$$\Rightarrow \frac{80}{FE} = \frac{5}{1}$$

$$FE = 16$$

Hence, the value of  $a = 16 \text{ m}$

6. (A) Area of each same square =  $\frac{125 \text{ cm}^2}{5}$   
 $= 25 \text{ cm}^2$

$\therefore$  Side of each small square = 5 cm

let the smallest side be  $x \text{ cm}$

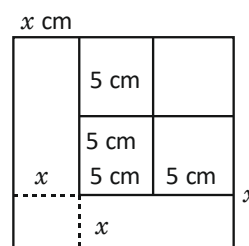

$$\therefore \text{Area of 'L' shaped part} = 10x + x^2 + 10x$$

$$= x^2 + 20x$$

$$\therefore \text{Given } x^2 + 20x = 25$$

$$x^2 + 20x - 25 = 0$$

$$a = 1, b = 20, c = -25$$

$$x = \frac{-b \pm \sqrt{b^2 - 4ac}}{2a}$$

$$= \frac{-20 \pm \sqrt{20^2 - (-204C_1)}}{2 \times 1}$$

$$= \frac{-20 \pm \sqrt{400 + 100}}{2}$$

$$x = \frac{-20 \pm \sqrt{500}}{2}$$

$$= \frac{-20 \pm 10\sqrt{5}}{2}$$

$$x = \frac{-20 + 10\sqrt{5}}{2} = 10^5(-2 + \sqrt{5})$$

$$= 5(\sqrt{5} - 2) \text{ cm}$$

7. (A) Given  $\frac{x}{1} = \frac{\sqrt{a+3b} + \sqrt{a-3b}}{\sqrt{a+3b} - \sqrt{a-3b}}$

$$\therefore \frac{x+1}{x-1} = \frac{(\sqrt{a+3b} + \sqrt{a-3b}) + (\sqrt{a+3b} - \sqrt{a-3b})}{(\sqrt{a+3b} + \sqrt{a-3b}) - (\sqrt{a+3b} - \sqrt{a-3b})}$$

$$\frac{x+1}{x-1} = \frac{2\sqrt{a+3b}}{2\sqrt{a-3b}}$$

Squaring on both sides.

$$\frac{x^2 + 2x + 1}{x^2 - 2x + 1} = \frac{a + 3b}{a - 3b}$$

$$\cancel{ax^2} + 2ax + \cancel{1} - 3bx^2 - \cancel{6bx} - 3b = \cancel{ax^2} - 2ax + \cancel{1} + 3bx^2 - \cancel{6bx} + 3b$$

$$0 = 6bx^2 - 4ax + 6b$$

$$\therefore 3bx^2 - 2ax + 3b = 0$$

8. (D) Let the three sides of a right angled triangle be  $a, a + d, a + 2d$  respectively  
[ $\therefore$  Given sides are in AP]

$$\therefore (a + 2d)^2 = a^2 + (a + d)^2$$

$$\cancel{a^2} + 4ad + 4d^2 = \cancel{a^2} + a^2 + 2ad + d^2$$

$$\Rightarrow a^2 - 2ad - 3d^2 = 0$$

$$a^2 - 3ad + ad - 3d^2 = 0$$

$$a(a - 3d) + d(a - 3d) = 0$$

$$\Rightarrow (a - 3d)(a + d) = 0$$

$$a - 3d = 0 \text{ or } a + d = 0$$

$\therefore a = 3d$  &  $a = -d$  rejected because side of triangle is always positive

$\therefore 3d, 4d$  and  $5d$  are the sides of a right angled triangle

$\therefore 80$  Unit is the side of a right angled triangle because  $80$  is multiple of  $4$  as well as  $5$

9. (C)  $\angle OQS = 90^\circ - 50^\circ = 40^\circ$

$$\therefore \angle OSQ = \angle OQS = 40^\circ$$

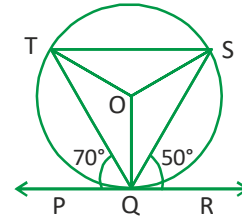

$$\therefore \angle OQS = 180^\circ - 40^\circ - 40^\circ = 100^\circ$$

$$\therefore \angle QTS = \frac{\angle OQS}{2} = 50^\circ$$

$$\angle TQP = 70^\circ$$

$$[\therefore \text{Given}] \Rightarrow \angle TQO = 20^\circ$$

$$\therefore \angle OTQ = \angle TQO = 20^\circ$$

$$\Rightarrow \angle OTS = \angle QTS - \angle OTQ = 50^\circ - 20^\circ$$

$$\therefore \angle OTS = \angle x = 30^\circ [\therefore OT = OS]$$

10. (D) In  $\triangle ABC$  given  $\angle B = 90^\circ$

$$\therefore AC^2 = AB^2 + BC^2$$

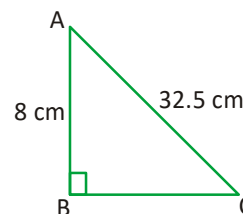

$$(32.5)^2 = 8^2 + BC^2$$

$$BC = \sqrt{1056.25 - 64} = \sqrt{992.25} = 31.5$$

Area of  $\triangle ABC$

$$= \frac{1}{2} \times AB \times BC = \frac{1}{2} \times 8 \times 31.5 \text{ cm}$$

$$= 126 \text{ cm}^2$$

11. (D) The required distance

$$= \sqrt{[(\sqrt{3}+1)-(\sqrt{3}-1)]^2 + [(\sqrt{2}-1)-(\sqrt{2}+1)]^2}$$

$$= \sqrt{(2)^2 + (2)^2} = 2\sqrt{2}$$

12. (Delete)

13. (D) Let the smallest integer be x.

$$\text{Given } \frac{30^{15}}{21} (x + x + 29) = 315$$

$$2x + 29 = \frac{315 \times 21}{151}$$

$$2x = 21 - 29 = -8$$

$$x = -4$$

14. (C) Const: Draw  $SV \parallel QU$

In  $\triangle QRU$ , S is the mid point of QR and  $SV \parallel QU$

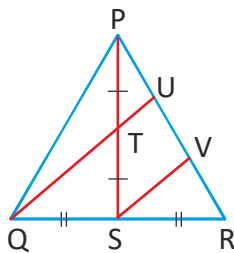

$$\therefore \frac{RS}{SQ} = \frac{RV}{VU} \quad [\because \text{Thales theorem}]$$

$$\therefore \frac{RS}{RS} = \frac{RV}{VU}$$

$$\Rightarrow RV = VU \quad \longrightarrow \textcircled{1}$$

In  $\triangle PSV$ ,  $TU \parallel SV$

$$\Rightarrow \frac{PT}{PS} = \frac{PU}{UV} \quad [\because \text{Thales theorem}]$$

$$\Rightarrow PU = UV \quad \longrightarrow \textcircled{2}$$

from  $\textcircled{1}$  &  $\textcircled{2}$ ,  $PU = UV = VR$

$$\therefore PU = \frac{1}{3} PR = \frac{1}{3} \times 24 \text{ cm} = 8 \text{ cm}$$

15. (A) Let  $a \sin \theta + b \cos \theta = y$

$$x^2 + y^2 = (a \cos \theta - b \sin \theta)^2 + (a \sin \theta + b \cos \theta)^2$$

$$= a^2(\cos^2 \theta + b^2 \sin^2 \theta - 2ab \sin \theta \cos \theta +$$

$$a^2 \sin^2 \theta + b^2 \cos^2 \theta + 2ab \sin \theta \cos \theta$$

$$= a^2(\sin^2 \theta + \cos^2 \theta) + b^2(\sin^2 \theta + \cos^2 \theta)$$

$$= a^2 + b^2$$

$$\therefore y^2 = a^2 + b^2 - x^2$$

$$y = \pm \sqrt{a^2 + b^2 - x^2}$$

16. (A)  $S = \frac{P}{2} = 12 \text{ cm}$

$$\text{Area of } \triangle = rs = 12 \text{ cm} \times 2 \text{ cm} = 24 \text{ cm}^2$$

17. (B) From C, draw  $CL \perp AB$  and from D, drawn  $DM \perp AB$

Then  $CL = DM$

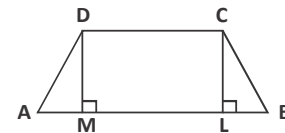

In  $\triangle ACB$ , since  $\angle B$  is an acute angle,

$$\therefore AC^2 = AB^2 + BC^2 - 2AB \cdot BL \dots (1)$$

Similarly, In  $\triangle ABD$ , Since  $\angle A$  is an acute angle,

$$\therefore BD^2 = AD^2 + AB^2 - 2AB \cdot AM \dots (2)$$

Adding (1) and (2), we get

$$AC^2 + BD^2 = AD^2 + BC^2 + 2AB^2 - 2AB \cdot BL - 2AB \cdot AM$$

$$= AD^2 + BC^2 + 2AB (AB - BL - AM)$$

$$= AD^2 + BC^2 + 2AB (AL - AM)$$

$$= AD^2 + BC^2 + 2AB \cdot ML$$

$$= AD^2 + BC^2 + 2AB \cdot CD$$

18. (D)  $\alpha = a - d$ ,  $\beta = a$ ,  $\gamma = a + d$

Given  $\alpha, \beta, \gamma$  are in AP

$$\Rightarrow \alpha + \beta + \gamma = -\frac{b}{a}$$

$$a - d + a + a + d = 9$$

$$3a = 9$$

$$a = 3$$

$$\alpha \beta \gamma = 21$$

$$(a - d)(a)(a + d) = -21$$

$$(3 - d)(3)(3 + d) = -21$$

$$(3 - d)(3 + d) = -7$$

$$9 - d^2 = -7$$

$$d^2 = 16$$

$$d = \pm 4$$

If  $a = 3$  &  $d = 4$  then  $a - d = -1$ ,  $a + d = 7$

If  $a = 3$  &  $d = -4$  then  $a - d = 7$ ,  $a + d = -1$

$$\therefore a + d - (a - d) = 2d = 8$$

19. (D)  $\cos 30^\circ \cos 45^\circ - \sin 30^\circ \sin 45^\circ$

$$= \frac{\sqrt{3}}{2} \left( \frac{1}{\sqrt{2}} \right) - \frac{1}{2} \left( \frac{1}{\sqrt{2}} \right)$$

$$= \frac{\sqrt{3}}{2\sqrt{2}} - \frac{1}{2\sqrt{2}}$$

$$= \frac{\sqrt{3}-1}{2\sqrt{2}} \times \frac{\sqrt{2}}{\sqrt{2}}$$

$$= \frac{\sqrt{2}(\sqrt{3}-1)}{4}$$

20. (A) If  $n = 0$  then  $\frac{a^{n+1} + b^{n+1}}{a^n + b^n} = \frac{a+b}{2}$  which is

Am of  $a$  &  $b$ .

21. (C) Given vertices form a right angled triangle. In a right angled triangle the vertex of right angle is orthocentre.

$$\therefore \text{Ortho centre} = (0, 0)$$

22. (D)  $BD = 2\sqrt{2}$

$$\therefore r = \frac{BD}{2} = \frac{2\sqrt{2}}{2} \text{ cm} = \sqrt{2} \text{ cm}$$

$$\text{Area of Circle} = \pi(\sqrt{2})^2 = 2\pi \text{ cm}^2$$

$$\text{Area of square} = 2^2 = 4$$

$$\text{Area of circle} - \text{Area of square} = 2\pi - 4$$

Area between circle and square on each

$$\text{side} = \frac{2\pi - 4}{4}$$

Area of shaded regions

$$= 4 \left[ \frac{\pi(1)^2}{2} - \frac{\pi-2}{2} \right]$$

$$= 4 \left[ \frac{\pi - \pi + 2}{2} \right] = 4 \text{ cm}^2$$

23. (C) HCF of  $\frac{5}{12}, \frac{10}{9}, \frac{25}{6}$  is  $\frac{5}{36}$

$$\text{LCM of } \frac{5}{12}, \frac{10}{9}, \frac{25}{6} \text{ is } \frac{50}{3}$$

$$\therefore \text{LCM} + \text{HCF} = \frac{5}{36} + \frac{50}{3} = \frac{5+600}{36} = \frac{605}{36}$$

24. (B) Const:-  $BD \perp AC$

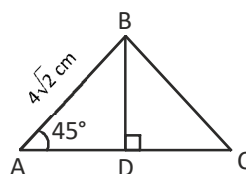

$$\text{In } \triangle ABD \sin 45^\circ = \frac{BD}{AB}$$

$$\frac{1}{\sqrt{2}} = \frac{BD}{4\sqrt{2} \text{ cm}}$$

$$BD = 4 \text{ cm}$$

$$\text{Area of } \triangle ABC = \frac{1}{2} \times BD \times AC = \frac{1}{2} \times 4 \text{ cm} \times 7 \text{ cm} = 14 \text{ cm}^2$$

25. (D)

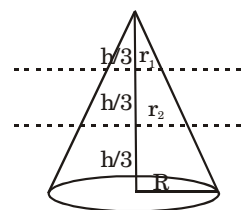

$$v_1 : v_2 : v_3 = \frac{1}{3} \pi \left( \frac{r}{3} \right)^2 \left( \frac{h}{3} \right)$$

$$: \left[ \frac{1}{3} \pi \left( \frac{2r}{3} \right)^2 \left( \frac{2h}{3} \right) - \frac{1}{3} \pi \left( \frac{r}{3} \right)^2 \left( \frac{h}{3} \right) \right] :$$

$$\left[ \frac{1}{3} \pi r^2 h - \frac{1}{3} \pi \left( \frac{2r}{3} \right)^2 \left( \frac{2h}{3} \right) \right]$$

$$= \frac{\pi r^2 h}{81} : \frac{7\pi r^2 h}{81} : \frac{19\pi r^2 h}{81}$$

$$= 1 : 7 : 19$$

$$26. (A) \frac{a_1}{a_2} = \frac{b_1}{b_2} = \frac{c_1}{c_2} \Rightarrow$$

They are dependent equations

$$27. (B) \text{ Given } \angle ACP = a^\circ \text{ and } \angle BPC = b^\circ.$$

from the figure,  $\angle APC = \angle APB + \angle BPC$

but  $\angle APB = 90^\circ$

( $\because$  angle in a same - circle)

$$\therefore \angle APC = 90^\circ + b^\circ$$

now in  $\triangle APC$ , we have  $\angle ACP = a^\circ$  and

$\angle APC = 90^\circ + b^\circ$  and  $\angle CAP = b^\circ$

( $\because \angle BPC = \angle CAP$  alternate angles)

$\therefore$  sum of 3 angles of  $\triangle APC$

$$a^\circ + 90^\circ + b^\circ + b^\circ = 180^\circ$$

$$a^\circ + 2b^\circ = 90^\circ$$

28. (A) Let OAB be the given cone cut off by a plane CD parallel to the base AB such that a small cone OCD is left.

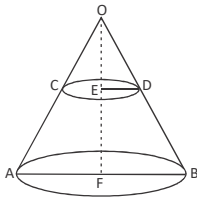

For the cone OAB :

Height  $H = 30$  cm

Let the radius of the base be  $R$ .

Then, Volume of the cone OAB

$$= \frac{1}{3} \pi R^2 h$$

$$= \left[ \frac{1}{3} \pi R^2 \times 30 \right] \text{cm}^3 = (10 \pi R^2) \text{cm}^3$$

For the cone OCD :

Let the height be  $h$  and radius of the base be  $r$ .

Then, the volume of the cone OCD

$$= \frac{1}{3} \pi r^2 h.$$

$$\text{New, } \frac{1}{3} \pi r^2 h = \frac{1}{27} (10 \pi R^2)$$

[given]

$$\Rightarrow \left( \frac{R}{r} \right)^2 = \frac{9h}{10} \dots (i)$$

Also,  $\triangle OED \sim \triangle OFB$  [ $\because OF = H = 30$  cm]

$$\therefore \frac{OE}{OF} = \frac{ED}{FB} \Rightarrow \frac{h}{30} = \frac{r}{R} \Rightarrow \frac{R}{r} = \frac{30}{h} \dots (ii)$$

From (i) and (ii) we get :

$$\left( \frac{30}{h} \right)^2 = \frac{9h}{10} \Rightarrow h^3 = 1000 \Rightarrow h = 10 \text{ cm.}$$

Thus, the height of the smaller cone OCD = 10 cm.

Hence, the height of the section from the base =  $EF = OF - OE = H - h = (30 - 10)$  cm = 20 cm.

29. (C)

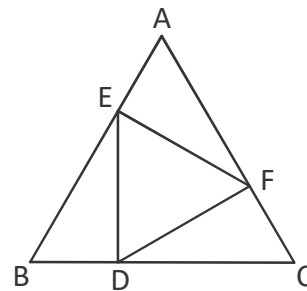

Let's take one of the smaller right triangles. Without loss of generality, let the smaller leg be 1. Since the triangle is a  $30^\circ - 60^\circ - 90^\circ$  right triangle, then the other leg is  $\sqrt{3}$  and the hypotenuse is 2. The side length of the bigger triangle is  $1 + 2 = 3$  and the side length of the smaller triangle is  $\sqrt{3}$ . The ratio of the areas of two similar triangles is the square of the ratio of two corresponding side lengths, so the ratio of the area of triangle DEF to the area of

triangle ABC is  $\left( \frac{\sqrt{3}}{3} \right)^2 = \frac{1}{3}$ .

30. (B) Circumference of circular path

$$= 2\pi r = 2 \times \frac{22}{7} \times 14 \text{ m}$$

$$= 88 \text{ m}$$

Time taken to cover 88 m to Narayana

$$= \frac{88 \text{ m}}{17.6 \text{ KMPH}} = \frac{88 \text{ m}}{17.6 \times \frac{5 \text{ m}}{18 \text{ sec}}}$$

$$= 18 \text{ seconds}$$

Time taken to cover 88 m to krishna

$$= \frac{88 \text{ m}}{26.4 \text{ KMPH}} = \frac{88 \text{ m}}{26.4 \times \frac{5 \text{ m}}{18 \text{ sec}}}$$

= 12 seconds

LCM of 18 seconds and 12 seconds is 36 seconds.

31. (B, C, D) Mid pt. of AB = (0, 2) ; length of median to AB =  $\sqrt{26}$

Mid pt. of BC = (3, 1) ; length of median to BC =  $2\sqrt{5}$

Mid pt. of AC = (2, 2); length of median to AC =  $\sqrt{2}$

Hence, option (A) is not the length of median.

32. (B, D) If  $\theta = 30^\circ$  then

$$81^{\sin^2\theta} + 81^{\cos^2\theta}$$

$$= 81^{\left(\frac{1}{2}\right)^2} + 81^{\left(\frac{\sqrt{3}}{2}\right)^2}$$

$$= 81^{\frac{1}{4}} + 81^{\frac{3}{4}}$$

$$= (3^4)^{\frac{1}{4}} + (3^4)^{\frac{3}{4}}$$

$$= 3 + 3^3$$

$$= 3 + 27 = 30$$

Similarly  $\theta = 60^\circ$  also

$$81^{\sin^2\theta} + 81^{\cos^2\theta} = 30$$

33. (B, C, D)  $\frac{a_1}{a_2} \neq \frac{b_1}{b_2} \Rightarrow$  consistent but unique solution

If  $\frac{a_1}{a_2} = \frac{c_1}{c_2}$  and either

$$\frac{a_1}{a_2} = \frac{b_1}{b_2} = \frac{c_1}{c_2} \text{ or } \frac{a_1}{a_2} \neq \frac{b_1}{b_2} = \frac{c_1}{c_2}$$

then the given lines are consistent

$$\frac{a_1}{a_2} = \frac{b_1}{b_2} = \frac{c_1}{c_2} \Rightarrow \text{the lines are consistent}$$

$$34. (A, C) \sqrt{3} \cot^2\theta - 4\cot\theta + \sqrt{3} = 0$$

$$\sqrt{3} \cot^2\theta - 3\cot\theta - \cot\theta + \sqrt{3} = 0$$

$$\sqrt{3} \cot\theta(\cot\theta - \sqrt{3}) - 1(\cot\theta - \sqrt{3}) = 0$$

$$(\cot\theta - \sqrt{3})(\sqrt{3} \cot\theta - 1) = 0$$

$$\cot\theta - \sqrt{3} = 0 \text{ (or) } \sqrt{3} \cot\theta - 1 = 0$$

$$\cot\theta = \sqrt{3} \quad \sqrt{3} \cot\theta = 1$$

$$\cot\theta = \cot 30^\circ$$

$$\theta = 30^\circ$$

$$\cot\theta = \frac{1}{\sqrt{3}} = \cot 60^\circ$$

$$\theta = 60^\circ$$

35. (A, B, C, D)

Let the three angles of a triangle are in AP be

$$a - d, a, a + d$$

$$\therefore a - d + a + a + d = 180^\circ$$

$$3a = 180^\circ$$

$$a = 60^\circ$$

$\therefore$  If  $d = 10^\circ$  then

$50^\circ, 60^\circ$  and  $70^\circ$  are in AP and angles of a triangle

If  $d = 30^\circ$  then  $30^\circ, 60^\circ$  and  $90^\circ$  are in A

If  $d = 2^\circ$  then

$58^\circ, 60^\circ$  and  $62^\circ$  are in AP

If  $d = 0^\circ$  then  $60^\circ, 60^\circ$  and  $60^\circ$  are also in AP.

36. (A) Z - V; C - B; X - N shows pairs opposite faces.

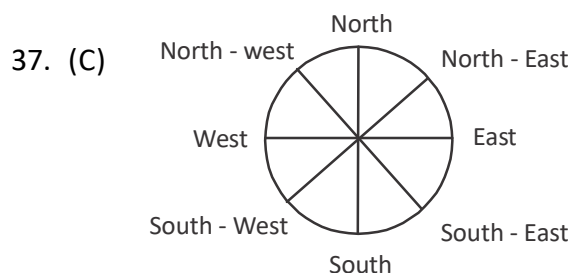

If South - East becomes North and North East becomes West, therefore, the whole figure moves through  $135^\circ$ . Hence, West will be South - East. See, Actual figure is rotating  $135^\circ$  anticlockwise. So When West will be rotated by same degree anticlockwise. It will hold the place of south - East.

38. (A)  $13^{\text{th}} \rightarrow 5^{\text{th}}$   
A B C D E F G H I J K L M N O P Q R S

39. (C)  $(1 + 9 + 2 + 7) \times 2$   
 $19 \times 2 = 38.$

40. (A) In all the other figures, both pin and arrow are in opposite directions and parallel to each other.

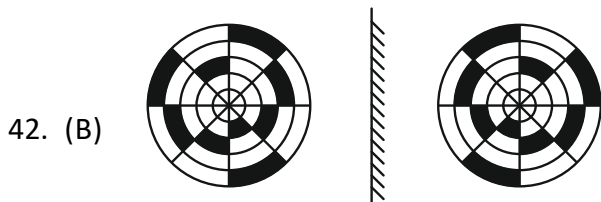
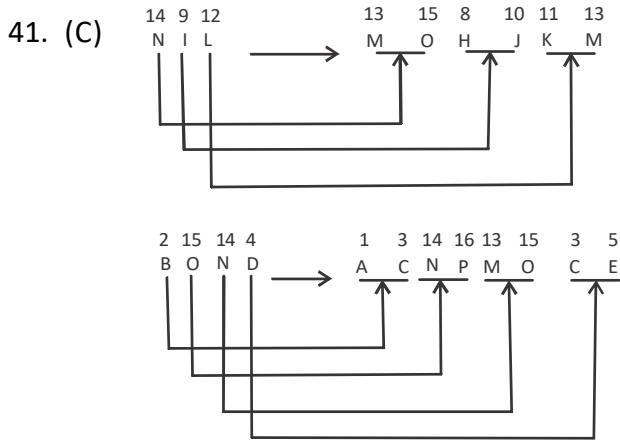

43. (C) The short arrow rotates  $45^\circ$  ACW and long arrow rotates  $90^\circ$  CW.  
Hence, option (D), should replace the question mark.

44. (A)  $4 \xrightarrow{+1^2} 5 \xrightarrow{+2^2} 9 \xrightarrow{+3^2} 18 \xrightarrow{+4^2} 34 \xrightarrow{+5^2} 59$

45. (C) There are 15 parallelograms in the given figure.

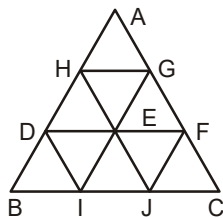

1. BDEI 2. EFJI 3. DEJI 4. EFCJ 5. DEGH
6. EFGH 7. EGAH 8. BHGI 9. GHJC 10. AGID
11. AFJH 12. DHEI 13. EGFI
14. DFJB 15. DFCI

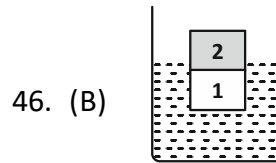

47. (D) To solve this question, you need to know how to set up a system of equations using the given information and how to solve for the unknown variable. Here is one possible explanation:

Let  $x$  be the number of bottles that Hari fills in one minute and  $y$  be the number of bottles that Shiva fills in one minute. Then, we have the following equations.

$x + y = 30$  (the total number of bottles filled by Hari and Shiva in one minute)

$$\frac{900}{30}$$

Statement 1 tells us that  $y = x/2$ , which means that Shiva fills half as many bottles as Hari in one minute. We can substitute this into the first equation and get:

$$x + x/2 = 30$$

$$3x/2 = 30$$

$$x = 20$$

This means that Hari fills 20 bottles in one minute and Shiva fills 10 bottles in one minute. We can use this to find how long it takes Shiva to fill the bottles by herself.

$$30y = 900$$

$$30(10) = 900$$

$$y = 30$$

So, Shiva takes 30 minutes by herself to fill the bottles. Therefore, statement 1 alone is sufficient to answer the question.

Statement 2 tells us that  $45x = 900$ , which means that Hari would take 45 minutes by himself to fill the bottles. We can solve for  $x$  and get:

$$x = 20$$

This is the same as what we found from statement 1, so we can use it to find how long it takes Shiva to fill the bottles by herself:

$$y = x/2$$

$$y = 20/2$$

$$y = 10$$



So, Shiva fills 10 bottles in one minute and takes 30 minutes by herself to fill the bottles. Therefore, statement 2 alone is also sufficient to answer the question.

Since both statements alone are sufficient, the correct answer is D. Each statement alone is sufficient.

48. (B)

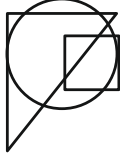

The dot should become under three region.

49. (B)

Three of the statements are correct, and only one digit is on the card. Thus, one of I and III are false. Therefore, II and IV must be true.

50. (D)

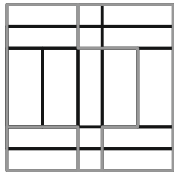

=====*The End*=====